

PARISH OF ST. PAUL STEWARDSHIP 2006

For this year's stewardship campaign, we recognize the many transitions St. Paul's faces, drawing on Ecclesiastes, (ch. 3, verses 1-11) for inspiration. In the days ahead, please take some time in prayer and reflection to consider the ways in which these changes are affecting you, the role St. Paul's plays in your lives and how you may wish to express your commitment to St. Paul's in the year ahead.

FOR EVERYTHING THERE IS A SEASON, AND A TIME FOR EVERY MATTER UNDER HEAVEN (v.1)

Change is all about us: comforting symbols are being reworked or rearranged, some friends have parted, new faces have appeared and the self study search process has commenced. Change can be unnerving and frightening – just as we begin to understand our surroundings, the walls move. Yet change can also promote healthy adjustment and growth. Faith in all its forms – in God, in our parish community and in ourselves – reassures, grounds and informs us as we embrace the changes yet to come – knowing that our journeys are enriched by life's persistent calls for growth and renewal and by our shared commitment to sustain our church and ourselves.

A TIME TO BE BORN, AND A TIME TO DIE; A TIME TO PLANT, AND A TIME TO PLUCK UP WHAT IS PLANTED (v.2)

Over the past year we have bid farewell to Maureen Kemeza and celebrated her many years among us as our rector and friend. We sang a joyous adieu to our music director Peter Cutts and gave him our heartfelt good wishes for his return to England. The Small Circle of Friends day care departed our undercroft and new faces now occupy the rectory. In the same period, we have been blessed to welcome Carol Flett as our Interim. With many years of experience at both the parish and diocesan levels, Carol's presence among us assures both continuing pastoral coverage and helpful guidance in changing times. At summer's end, we welcomed our new music director, Reiko Akasaka, into our parish family. Our Sunday services have already reaped the benefit of Reiko's extensive musical training and boundless enthusiasm.

A TIME TO BREAK DOWN, AND A TIME TO BUILD UP (v.3)

The past year has been (and continues to be) one of numerous tangible and programmatic accomplishments. Some concrete examples include:

- new gutters for rectory
- major repairs to furnaces

- new computers for offices
- air conditioner in rector's office
- improved office communications
- fire protection being upgraded and
- completion of first audit of parish finances in several years

None of these substantial and varied accomplishments occurred by themselves. Rather, they reflect the caring and faithful participation of our fellow parish members.

Transitions have not slowed down our programs at St. Paul's. In the last several months, dedicated parishioners have expanded our use of the meditation garden for summer services and have organized a special 9/11 memorial service within its space. Our own Maeve Ward has been awarded for her many efforts to elevate environmental consciousness within our community. Christian Formation has been reorganized and enhanced to provide appropriate grade level materials and programs to multiple classes. Thanks to the tireless efforts of members of the Christian Formation Commission and our Belize Mission volunteers, we applied for and received from the diocese a \$3,000 grant for Sending and Serving for Mission Belize and a \$7,400 grant for Congregational Development to fund a series of community forums. Our cooperation with other Newton parishes included Mission Belize, a Progressive Dinner and a Lenten reading series. We feted our Rite 13 participants and held

several brown bag suppers to encourage on-going fellowship.

St. Paul's Outreach Committee members remain as active as ever - involving the parish in Salvation Army dinners, supporting the Epiphany School in Dorchester, tsunami and hurricane relief, Grow Clinic food drives, a summer day camp in Somerville and the Christmas Angel program (providing 25 families with clothes and toys).

In recent months, dedicated members of St. Paul's Knitting Ministry have knit shawls to comfort and warm the sick and homebound, made mittens and baby blankets for the Grow Clinic and blankets for presentation to the newly baptized.

A TIME TO KEEP SILENCE, AND A TIME TO SPEAK (v.7)

The words "Timing is everything" apply especially well to a period of transition in a faith community. "Pray before you speak" is another relevant and wise instruction. Now is the time for you to pray and to voice your hopes for the many ministries of St. Paul's. This is not a time to keep silence. The Search committee has gathered results of the parish-wide survey and small group discussions are planned in coordination with this year's Stewardship Campaign. You are invited to attend one of six gatherings where Vestry, Search and Stewardship representatives will listen to your ideas

and concerns. Please attend, pray together and then speak up. God is listening and will provide what and who you need to carry on Christ's ministry.

**GOD HAS MADE EVERYTHING
SUITABLE FOR ITS TIME AND HAS
PUT A SENSE OF PAST AND FUTURE
INTO THEIR MINDS (v.11)**

While we know there is a time for everything, God acts mysteriously in both our lives and our parish. We stand in awe of God's love, wisdom, mercy and justice, and put our trust in God. God has a purpose for St. Paul's and has given us minds and hearts to celebrate and learn from our past and to discern God's hope for your future. And yet it takes time for a new vision to take hold. Be patient with yourselves and with God.

DREAMS AND GOALS

We have shown no shortage of ideas in how we might expand programs and work to share our resources with the community in which we live.

As we look forward to the day when we call a new rector, a potentially daunting financial challenge looms before us. Were we to call a full-time rector who would live in the rectory and who did not already have an alternative source of health insurance, we calculate we would need to increase our parish income on an annual basis by nearly 42% or \$40,000.

This fiscal reality awakens us to the need to be conscious of our expenses and creative and flexible to these challenges.

Beyond the active search process and its implications to our budgets in the years to come, Vestry is currently considering and appraising the following potential capital improvement projects at St. Paul's:

- handicapped-accessible bathroom
- main floor kitchenette
- new furnace and hot water heater
- updated kitchen
- undercroft floor repair and
- "Safe Church" recommended changes to our offices.

All of these are substantial and will require both significant planning and real expense.

2006 PROJECTED FINANCIALS

Even without taking on any new capital improvement items, in order to reach our income goal for 2006, pledges must increase. Of critical note, while our average pledge per family in 2005 at St. Paul's was \$2,278, fully 55% of pledge income came from just nine families.

St. Paul's 2006 operating budget, currently projected at \$162,300, is reflected in the following two charts. The first shows the projected sources of income the second shows the anticipated major expense categories. Based on recent history, your pledges account for

60% of parish income which in turn is used to fund salaries and programs, maintain our property and support the work outside the parish.

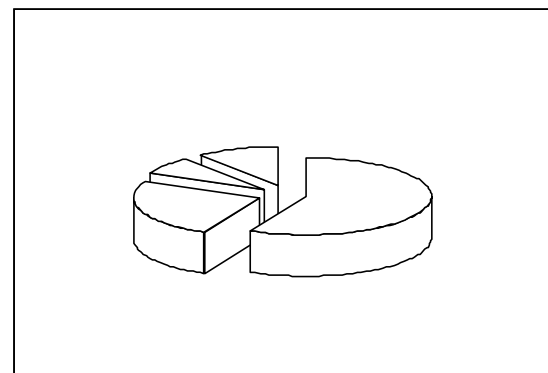
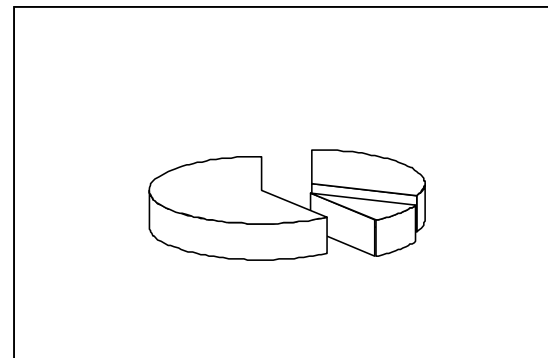

GIVING TO ST. PAUL'S

We are all able to share our wealth and time in different ways and amounts. Vestry encourages parishioners to consider stewardship in terms of proportional giving. Although the amounts each gives will differ (and all parishioner gifts are confidential) each

parishioner, regardless of means, knows (s)he is committed just as deeply in the stewardship life of the parish as other parishioners giving the same percentage of their income. When we think of our own giving as a proportion of our gross annual income, we can more clearly measure our personal progress toward the biblical goal of the tithe (10% of gross annual income).

"I realize salvation is free...but what is the suggested donation?"

We ask all parishioners to devote time in careful consideration of what level of support they can offer St. Paul's in 2006. To assist you in this discernment process, a proportional giving chart can be found on the back side of the enclosed pledge card. Please return the card to a member of Vestry on or before our planned in-gathering on Sunday, November 6, 2005.

Thank you for any and all expressions of interest in sharing your time, talent and treasure with the Parish of St. Paul.